

# Real time Noise and Air Pollution Monitoring using Arduino UNO and IoT

T. ANWESHA, ASSISTANT PROFESSOR, anweshat9f@gmail.com  
G. JYOTHI, ASSISTANT PROFESSOR, gunturujyothi9@gmail.com  
R. VASIM AKRAM, ASSISTANT PROFESSOR, vasim487@gmail.com  
Department of ECE, Sri Venkateswara Institute of Technology,  
N.H 44, Hampapuram, Rapthadu, Anantapuramu, Andhra Pradesh 515722

Abstract— Climate change, noise, water, and air pollution, among other environmental crises, are on the rise due to the exponential growth of the human population, industrialization, infrastructure expansion, automobiles, and fossil fuel use. Keep an eye on these problems and find ways to fix them if you care about people's health and the future of our planet. As a new area of study, smart sensor networks have the potential to aid in the monitoring of air pollution and noise levels by integrating electronics, wireless communication, and computer science. Using a wireless embedded computer system, this article offers a way to monitor the levels of noise and air pollution in any given region. The Internet of Things (IoT) links every component of the system, including the ESP8266, Xmega 2560, WiFi, dust, gas, humidity, and temperature sensors, and sound detectors. In order to document the gathered data on sound and air quality, the ThingSpeak environment is used. The authorities are notified anytime the pollutant level rises over a certain threshold. Arduino, ThingSpeak, WiFi, embedded system, and the Internet of Things are all relevant terms.

## I. INTRODUCTION

People are exposed to various health concerns with the increasing noise and air pollution. Noise and air pollution is mainly caused by growing industrialization and urbanization. Excessive utilization of energy resources and gases like NO<sub>2</sub>, NO,

SO<sub>2</sub>, CO<sub>2</sub> and so on are some of the significant sources for air pollution. Traditional ways of pollution monitoring were a tedious and inefficient task [1]. With the advancements in technology, several new techniques are introduced for fast and efficient pollution monitoring. Internet of Things (IoT) technology provides promising opportunities in this domain. It enables data exchange between the electrical and appliances, internet and humans with the help of numerous sensors. Low cost, efficiency and feasibility contributes to the success of IoT [2]. Noise and air pollution are the major constituents that impose adverse effects on human health and the environment. [3-5] It is essential to monitor and control such pollution. Dataloggers manually visited the site for data collection in traditional techniques for comparison and analysis of the information. This technique is time consuming and inefficient [6]. ]

This paper introduces a monitoring system that enables continuous monitoring and checking the air and sound quality and reports the

respected authorities if the pollution goes beyond the nominal level. An array of sensors are used for detecting noise pollution and for monitoring the level of concentration of harmful gases like Sulphur dioxide and carbon dioxide that pollutes the environment [7]. Data monitored from the IoT sensors are constantly transmitted to the microcontroller. The output from the sensors is stored in the cloud environment and made available for remote users. It is also possible to perform comparison with custom made algorithms and previously stored data from the cloud. This paper provides the procedure involved in construction of the prototype model for controlling noise and air contamination and alerting the authorities when the threshold level increases so that the necessary action can be taken at the earliest possible time and the situation may be restrained.

## II. LITERATURE REVIEW

Various environmental parameters are monitored and considered in most pollution monitoring systems in today's scenario. Several researches have made remarkable contribution in this domain [8]. Commercial meters such as ForbixSemicon, Amprobe, Fluke and so on are available in the market for detection of leakage of gases like LPG, carbon monoxide and carbon dioxide. For monitoring air quality and noise pollution level, several systems based on Geographic Information System (GIS) [6], Global System for Mobile Communication (GSM) [7] and Wireless Sensor Network (WSN) [9] technologies are proposed by many researchers. However, based on its intended function, every technology has certain limitations. The

pinpoints of pollution in specific areas can be monitored using GIS based system. It comprises of a memory buffer, mobile unit, sensors, microcontroller and internet connectivity. through web server for collection of data from multiple locations with information regarding time of the day and coordinates [6]. In a closed space and time, readings are averaged for a specific location. The source of pollution in any area can be represented accurately using the Global Positioning System (GPS) [10] module. A General Packet Radio Service (GPRS) [11] connection is used for periodic transmission of the recorded data to a computer. With the acceptance of the user, a dedicated website displays the recorded data.

## PROPOSED SYSTEM

Arduino Uno processor is used in the proposed noise and air pollution monitoring system with IoT. Port 9600 is used for providing a 5V DC power supply to the Arduino board. Sound and gas sensors are used for continuously monitoring the noise and air pollution level. Data picked by these sensors are provided to the Arduino and are continuously displayed on the LCD. Pins 2-5, 11 and 12 of the Arduino board are connected to the LCD display. The output is displayed in an analog format if the pollution exceeds a set limit. The 3.3 Volts pin on the Arduino board is connected to the Wi-Fi (nRF24L01) module. The sensor-based information is transmitted to the WiFi module for communicating with the respective authorities. Figure 1 provides a simulated architecture of the proposed noise and air pollution monitoring system.

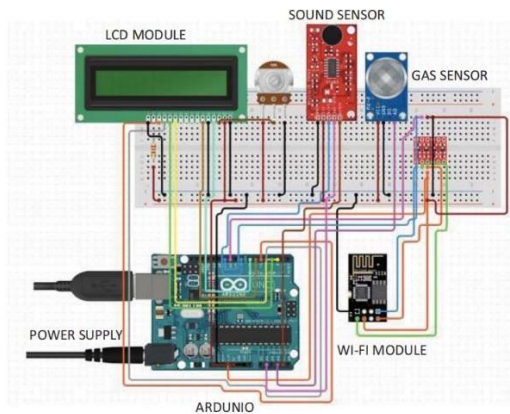

This model is designed exclusively for monitoring and evaluating the level of noise pollution and air quality to satisfy the need of the community in any specific area using IoT. Harmful compounds and gases like carbon monoxide, hazardous gases, alcohol, butane, propane, methane and so on are monitored in the atmosphere using the gas sensor. The sound sensor tracks the level of noise in the environment. The air pollution data is gathered by an MQ135 sensor and the noise level is captured by the sound metal module [12]. The sensors continuously interact and transmit the obtained data to the Arduino processor [13-15]. A wi-fi modem is installed for transmitting this information to a remote location. The buzzer alerts whenever air pollution is detected. Continuous blinking of LED is used to notify increase in noise pollution. This system assists the authorities as well as the public to view the information regarding pollution and contribute towards controlling it at their possible level.

This helps in building a stronger community and a better planet. Similar digital devices are installed on ambulances. Significant energy cost can be reduced as the energy consumption modules are available in the system and low power sensors and hardware modules are used. In order to provide practical and flexible

communication, the IoT based system design is used in the hardware architecture. The basic electrical data can be used for detecting issues related to the hardware connectivity. Trained or qualified professionals are not required for using this device as it is user friendly and the data can be read by common man. Wi-Fi module enable quick data transmission over long distances and ease of data access.

## HARDWARE AND INTERFACING

This section discusses the interfacing of hardware and software models in the proposed system. Figure 2 represents the prototype of the proposed system. The ESP8266 wi-fi module is connected to Arduino. It requires a voltage of 3.3V for functioning. Chip power-down (CH\_PD) and VCC of the wi-fi module are connected to the 3.3V pin on Arduino. The RX pin of the Wi-Fi module also requires 3.3V operational voltage. However, when directly connected to the Arduino board, it does not communicate information. Due to this reason, the 5V in Arduino is converted into 3.3V using a voltage divider module. For this purpose, three resistors are connected in series to form the required circuit. Pin 10 on Arduino is connected to the TX pin of ESP8266 module and pin 9 of Arduino is connected to the RX pin of the wi-fi module through resistors.

Internet and Wi-Fi access is provided to the project using the ESP8266 module. The device is of low cost and adds huge benefits to the system. It is one of the most prominent devices in the IoT platform that can communicate with almost any microcontroller. MQ135 air quality sensor is connected to Arduino. The sensor's VCC and ground pins are connected to the 5V and ground pins of the Arduino processor

respectively.

Further, the sensor's analog pin is connected to Arduino's A0 pin. A buzzer is connected to the 8th pin of Arduino for providing alert when the level of air pollution crosses the predefined threshold value. CO<sub>2</sub>, smoke, benzene, NO<sub>x</sub>, NH<sub>2</sub> and some other gases can be sensed by the MQ135 sensors which make it a perfect choice for air quality monitoring. The level of pollution is measured in terms of parts per million (PPM) by the gas sensor. The data is obtained as voltage level by the MQ135 gas sensor. This data is transmitted to the Arduino processor where it is converted into PPM using the MQ135 sensor library. This sensor can detect pollution in the range of 10- 10,000 PPM. 350PPM is designated as the safe level of air quality. During initial test conditions, the sensor provided a value of 90PPM when there was no gases detected. Sensor value beyond 1000PPM is set as harmful and toxic. At this level, people are affected by stuffy, stale and stagnant air causing drowsiness and headaches. When the level exceeds beyond 2000PPM, several diseases and increased heart rate may occur. The LCD displays —Gas Level Normal when the sensor value is less than 1000PPM. The buzzer alerts when this value goes beyond 1000PPM and the LCD displays —Gas Level High. Further, if the level reaches beyond 2000PPM, the buzzer alert continues and the LCD displays —Gas Level Dangerous. The system continuously monitors the sound level and reports it to the Arduino processor. This enables monitoring noise pollution near honking areas, hospitals and schools. Elevated sound levels cause negative psychological and physical health consequences leading to sleep disturbances, annoyance, ischemic heart

diseases, hypertension, tinnitus and hearing impairment. The average noise level permitted for residential areas is 50 dB. When the level reaches beyond this threshold, the LED blinks continuously and information is transmitted to the LCD display as well as to the respective authorities to take necessary action.

## RESULTS AND DISCUSSION

The module is tested before implementing the prototype for making necessary modifications and ensuring the system to be error free. Several test conditions are set and the system is exposed to multiple air and noise pollution environments. The users test the reports for ensuring the ease of access and user friendliness of the device. represents the indication of high noise pollution level, high air pollution level and no noise or air pollution using IoT based Thing Speak environment.

Data is gathered from entirely different devices that serve a single purpose and interest. Further, this information is transmitted to an online server mechanically. The data regarding variation in air pollution and sound intensity is tracked and monitored online

through the ThingSpeak environment from remote location as well as the LCD display at the area of installation. The information from the surroundings is collected and analysed using the sensors. Air quality is categorized as fresh air when it is less than 500PPM, poor air when it is between 1000 to 2000PPM and dangerous when it is beyond 2000PPM. Similarly, sound quality is acceptable when it is less than 50dB and poor when it reaches beyond this level. represents the display of air and noise

level in the LCD interface connected to the Arduino module.

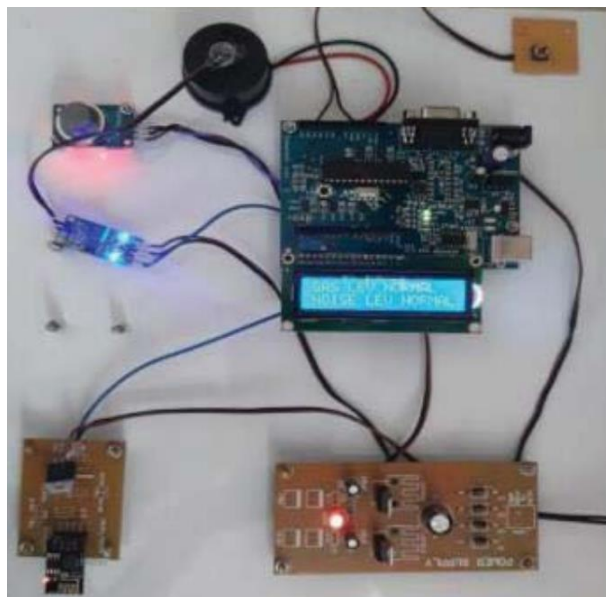

## VI. CONCLUSION

This study tackles the prevalent problem of environmental contamination in a straightforward and effective way. Air and sound quality may be continuously monitored and recorded by the system. Through the ThingSpeak environment and LCD display, this data is shown graphically. When pollution levels rise over a certain point, an alarm is sent out. This technique could be useful for quite a few places, including places with a lot of pollution, factories, hospitals, residential areas, places with a lot of traffic, and hospitals. Most notably, this model is easy to use, efficient, has minimal power consumption, and speeds up data transmission without sacrificing cost. Any location may have it placed. Through the internet interface, this data may be monitored and analysed in real-time, regardless of where you are. We want to commercialise this technology as a product and install numerous prototypes to assess their efficiency in the future.

## REFERENCES

- [1] Saha et al. [1] include Sircar, Dutta, Chatterjee, Chatterjee, A., Mitra, and Chatterjee. Hi Saha, H. N. (January of 2018). A cloud-based air and noise pollution monitoring system that senses humidity and temperature, operated by a Raspberry Pi. At this year's 8th Annual Computing and in 2018

Workshop and Conference on Communication (CCWC) (pp. 607-611). IEEE.

Next, we have Nowshin and Hasan. twenty-first January. An Environmental Pollution Monitoring System Based on a Microcontroller

via the Internet of Things (IoT). The IEEE 2nd International Conference on Robotics will be held in 2021. [3] "The Power of Sound—Can We Hear Air Pollution?" (Morgan & Shallcross, 2000).

Researchers Zhao, Deng, Zhang, Di, Jiang, and Li found [4] in their study. The year is 2021. Using machine learning to identify air contaminants based on beehive sounds. Journal of Ecological Informatics, 10, 1246. This is cited as [5] by De Carvalho and Szlafsztajn. F. this year (2019). Loss of urban vegetation and ecosystem services: how it affects pollution, noise, and climate control. Scientific Reports, 245, 844-852.

[2] Cetin, M., Onac, A. K., Sevik, H., & Sen, B. (2019). Temporal and regional change of some air pollution parameters in Bursa. Air Quality, Atmosphere & Health, 12(3), 311-316.

[3] Dige, A. S., & Tandle, S. R. A REVIEW: AIR POLLUTION MONITORING SYSTEM USING IOT.

[4] Barton, B. T., Hodge, M. E., Speights, C. J., Autrey, A. M., Lashley, M. A., & Klink, V.